

Article Info

Received: 15 Feb 2020 | Revised Submission: 29 Feb 2020 | Accepted: 08 Mar 2020 | Available Online: 15 Mar 2020

Design and Fabrication of Low-Cost Wood Working Mini CNC Milling Machine for Students Skill Development

Pulkit Bhasin, Praveen Singh** and Satnam Singh****

ABSTRACT

This paper presents the work on design and fabrication of a low cost three axis mini portable CNC milling machine; using Arduino Microcontroller, stepper motors and GRBL Shield. The present work is an attempt to minimize the overall cost of the computer numeric control machines while maintaining the accuracy of working. The low-cost machines will help in the skill development initiative started by Indian government for quality work force. This machine will target the budding entrepreneurs/wood workers to create intricate designs on work pieces at minimum investment, as compared to the existing commercially available CNC milling machines; which are very costly and bulky. The intention is to maintain the same output (in terms of accuracy and repeatability) as that of existing large machines while reducing its size and price. The machine is designed by considering various facets of the machine such as aesthetics, reliability, safety, performance and financial value. In this era of competitive markets, this machine will help the workers in rural areas and will play a crucial role in strengthening their manufacturing capabilities and enhancing the economic development of nation.

Keywords: *Computer numeric control; Arduino uno controller; G and M code; Repeatability; Accuracy and skill development.*

1.0 Introduction

The application of CNC machines in the manufacturing sectors is increasing at an alarming rate due to the productivity enhancement, improved product quality (in terms of dimensional tolerances), low cost of manufacturing and ease of utilization [1-3]. However, the cost associated with such machines hinders its full utilization capacity and small craftsmen are still deprived from the benefits of such machines. As per the report [4] available, there is still huge potential for various CNC machines for manufacturing sectors. A lot of awareness and skill developments programmes are started by government of India [5] to improve the quality of workforce, to impart advance knowledge of machines and to generate self-employment in various manufacturing sectors. However, to accomplish the targets, various

subsidies and loan approval systems are approved for micro, small and medium enterprises (MSME) [6]. The utilization of CNC machines can further be targeted in rural areas by reducing the cost of machines and by providing proper training to the workers. Pinhiero et al. [7] designed the mini CNC plotter using the Arduino microcontroller, which is low cost and can be operated easily. Further, researchers [8-10] have reported the application of Arduino microcontroller in many CNC based machines due to its ease of availability, cost effectiveness and ease of programming. The present project was started by keeping all the needs stated above in terms of low cost and accuracy of CNC machines. The work was started with a market survey and feasibility study of project was carried out. Through literature available [1,3, 8-10], it was found that there is a huge need of a low cost,

**Corresponding author; Department of Mechanical Engineering The Northcap University, Gurgaon, Haryana, India (E-mail: pulkitbhasin14@gmail.com)*

***Department of Mechanical Engineering The Northcap University, Gurgaon, Haryana, India (E-mail: praveensingh@ncuindia.edu)*

****Department of Mechanical Engineering The Northcap University, Gurgaon, Haryana, India (E-mail: satnamsingh@ncuindia.edu)*

lightweight, portable small-scale CNC machines that can be used for manufacturing with ease. The utilization of Arduino based microcontrollers are versatile and can be used in multi-disciplinary projects [11-13].

Based on the market research and requirements; design of low-cost CNC machine was started and finalized using design software (CATIA V5). The machine structure was fabricated using medium density fireproof wood and was interfaced with computer through Arduino Uno and GRBL Shield. This machine is a portable mini CNC milling machine which can be used for manufacturing prototypes in small-scale industries and can be used for educational purposes. Small to medium enterprises (SME's) in India are facing large problems like increase in domestic and global competition, working capital shortages, insufficient skilled labour, supply chain inefficiencies change in marketing strategies and turbulent market scenario. Designing and fabricating of ergonomic CNC machine, which is affordable and precise can offer a big hand towards small enterprise. Small business/artists/woodworkers could save a lot of money with cheaper alternatives, while enhancing the output rates.

2.0 Research Method

The most important parameter for any CNC machine is the precise movement of axis and calibration of motion either of the tool/workpiece. The movements of the axis can be calibrated by performing the measurement on standard test piece. This test was performed to acquire the data and to check whether the stepper motors and system are working according to the program configured. The next step was aimed at setting reference position of the spindle on the work piece using Universal G Code sender software. The tool was held in spindle, which was connected to a dc motor and rotated at fixed speed of 1200rpm (rotations per minute). The speed was confirmed by using tachometer. The next step after calibration and setting reference position was to upload .gcode extension format to Arduino Uno R3 using Universal G code sender through USB serial communication port. The function of microcontroller was to read the command and instruct the Nema stepper motor driver to perform the function in all three axes X, Y, Z which will further engage tool and workpiece to cut a profile.

Table 1: List of Materials Used for Fabrication

Material/ Components Used	Specifications
1. NEMA Stepper Motor	Step angle- 1.8 / pulse 200 pulses/Revolution = N
2. DC Motor (for spindle)	N = 12000 RPM
3. Linear Guides & Lead Screws	Material: Stainless Steel (SS316) Diameter – 8 mm Length – 400 mm Lead – 8 mm
4. Medium Density Firewood	MDF, 6mm thickness for fabricating frames, sheet length 2440mm and width 1220mm
5. Arduino Uno R3 Board (Data Processing Unit)	Arduino Uno R3 with AT Mega 328 chip Flash Memory: 32KB
6. Collet Chuck	Collet with extra grip force
7. GRBL Board (Control Loop Unit)	Grbl 0.8C Compatible (Open source firmware) Runs on 12V-36V DC
8. Stepper Motor Driver	16 pins driver, 28V DC with Overloading protection, output current upto 5Ampere
9. SMPS	Switch Mode Power Supply for powering the stepper motors and spindle
10. L-Shaped and U-Shaped Brackets	4 holes on each side for better grip

3.0 Construction of 3 Axis Arduino Based CNC

3.1 Material used

The various materials and electronic parts used in the construction of CNC machine are presented in the Table 1, with specifications.

3.2 Mechanical and electrical design

This section presents the details on designing of frame along with the electrical components and their connections used in the fabrication of machine.

3.2.1 Mechanical design

In this stage, the mechanical design of conventional machine was taken into consideration and then scaled down to a smaller size after minimizing the complex features. The initial design of machine frame was drafted for obtaining initial dimensions of the machine to be fabricated. After this 3D CAD design was prepared using CATIA V5 as shown in Figure 1.

Figure 1: Final 3D CAD of CNC Machine Model

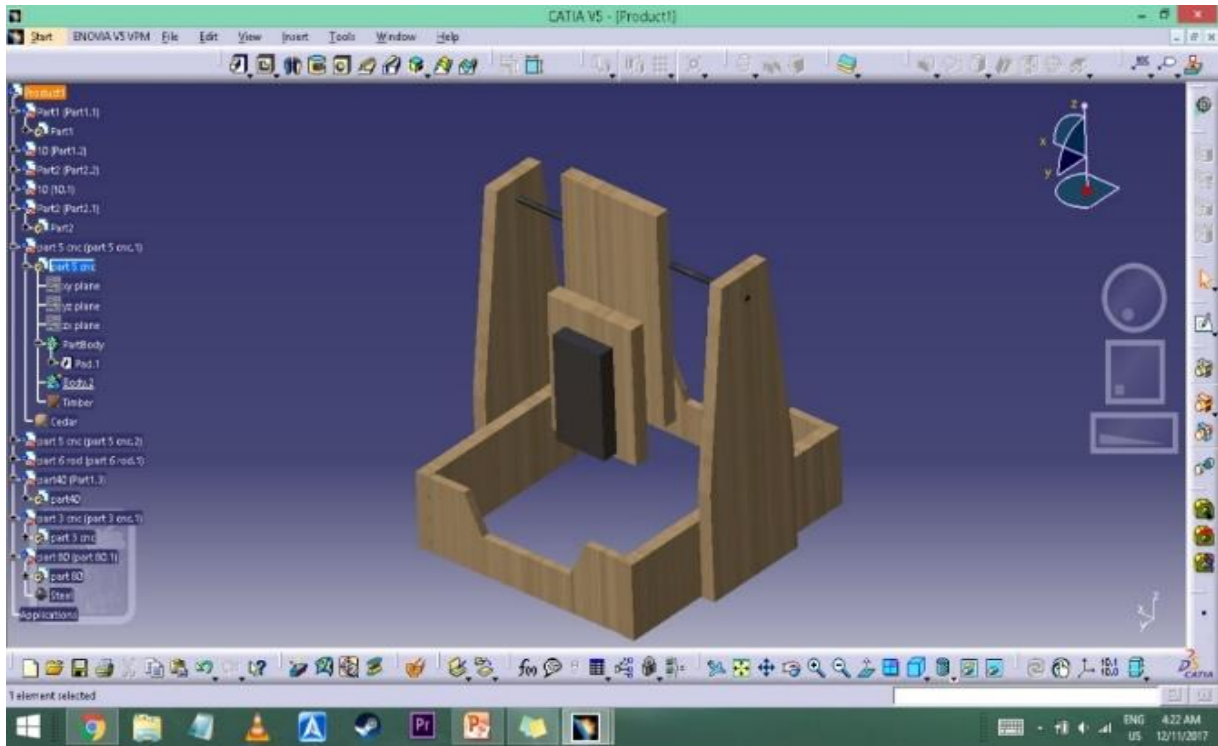

The drawing of each separate part and component was drawn in CATIA which includes base frame, gantry Y-axis frames, X-axis frame, Z-axis frame, linear guides. Then all the components are assembled in CATIA software to obtain the Final machine design.

3.2.2 Electronic design

The Switch Mode Power Supply (SMPS) was used to provide power supply to the Arduino Based mini cnc machine. Any personal laptop, computer can be used as a device to run softwares such as Universal G Code Sender, Xloader, IDE for Arduino Uno R3 and can also be used to instruct by sending image/design file to Arduino using USB cable as serial communication. A 28V DC and 16A power supply was used to drive the stepper motor driver. The circuit diagram of the machine is shown in Figure 2.

3.2.3 Machine fabrication

The final phase includes all the electrical connections made to control and operate the CNC machine with accuracy and precision. The machine is

operated and controlled with the help of Machine Control Unit which acts as the brain of the machine.

Control unit comprises of Arduino Uno (Data Processing Unit) and GRBL shield (Control Loop Unit). The fabricated mini CNC machine is shown in Figure 3 and complete technical specification of the fabricated machine is shown in Table 2.

Table 2: Technical Specifications of the Fabricated Machine

Parameter	Specification
Length	45 cm
Breadth	40 cm
Height	50 cm
X Axis working length	38 cm
Y Axis working length	36 cm
Z Axis working length	42 cm
Screw	M6 Threaded Rod (8mm dia and 1.2mm pitch)

Figure 2: Electronic Circuit Design for 3-Axis CNC Milling Machine

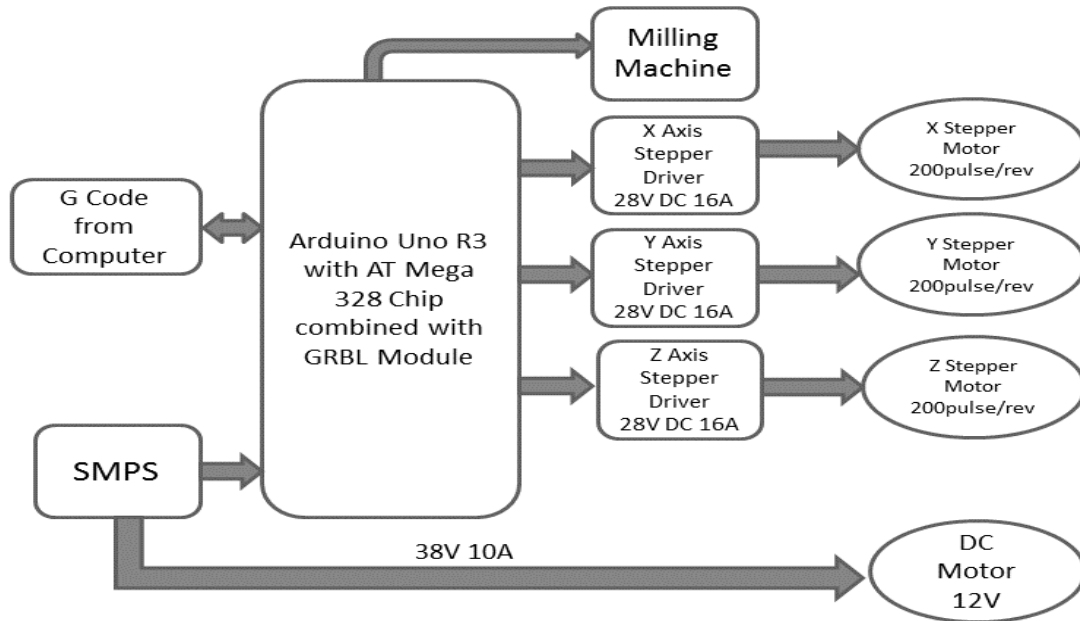
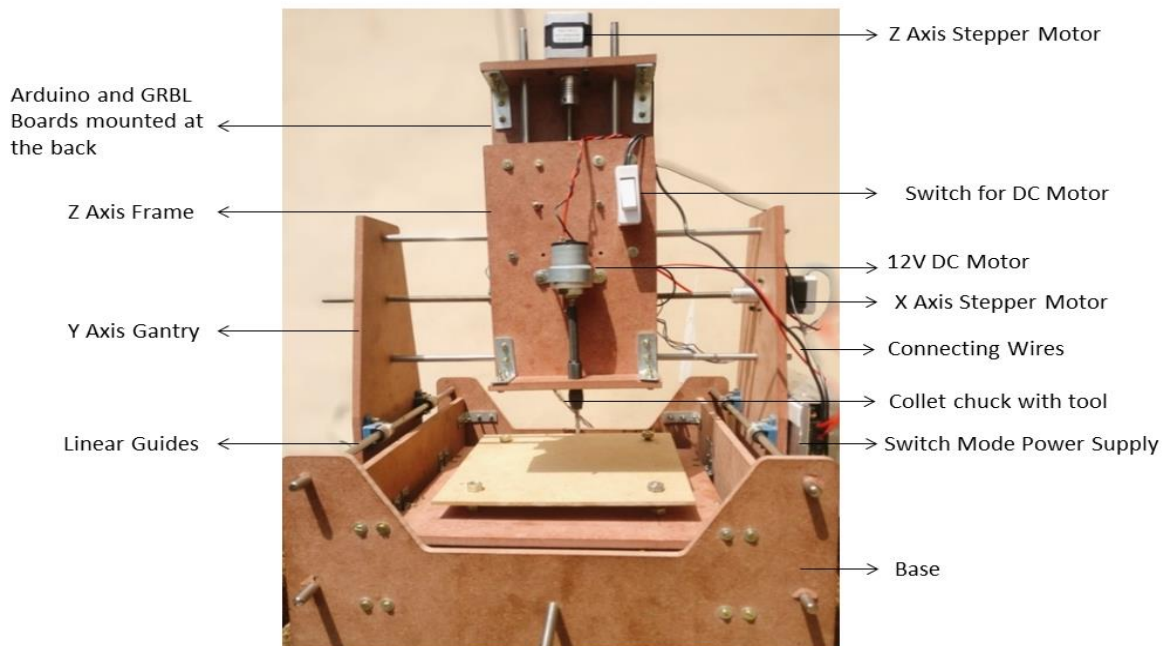

Figure 3: Fabricated Mini CNC Milling Machine



4.0 Machine Test Results

The accuracy and repeatability are the two major characteristics of any computer numeric controlled machine. To study these parameters various tests were carried out. In this section the output results of various tests are reported which proved the reliability of fabricated CNC machine.

4.1.1 Coordinate marking system test

This test is used to check the accuracy of the tool movement provided through axis stepper motors and directly relates to the precision in manufacturing operations. To carry out this test, a G-Code programme was set to move the tool from edge of workpiece to the desired locations and then measuring the coordinates of those marked points

through Coordinat Measuring Machine (CMM). Firstly, a programme to mark 4 coordinates on the work piece where one corner ‘O’ is considered to be the origin with value (0,0) and four points with coordinates A (3,3), B (3,6), C (6,6) and D (6,3) was prepared (Refer Figure 4).

The next step involves generating command to calibrate machine to the starting point and the origin was set into the machine. The tool drills into the coordinates programmed in the software and these drilled points were measured on CMM.

Figure 4: Coordinate Measuring Test for Checking Accuracy of Machine

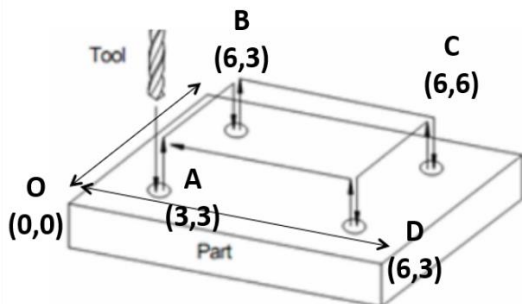

After analyzing the ten drilled specimens, results of CMM revealed good accuracy of machine with 98.82% repeatability capability.

4.1.2 Engraving system test

The engraving tests were performed on wood and acrylic sheets of 18 mm thickness, using drill bit of size 3mm and spindle speed of 12000rpm . The engraving depth was set to 4 mm and output of engraving tests are shown in Figure 5. The results shows good accuracy of 99.2% as measured by CMM for engraving depth throughout the sample.

Figure 5: Engraving Test Results

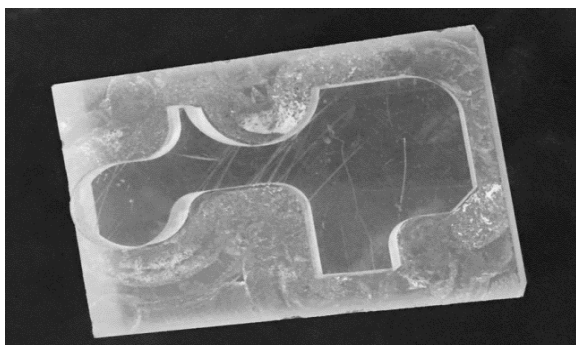

4.1.3 Drilling system test

The drilling test was performed on wood and mdf with 14 mm thickness using drill bit of size 3mm v60 bit with spindle speed of 12000rpm. The drilling depth was set to 4 mm and drilled holes are shown in Figure 6.

Table 3: Job Specifications for Measuring the Accuracy of Machine

Length	60.000 mm
Width	30.000 mm
Contour Depth Z	5.000 mm
Decimals	3

Figure 6: Drilled Holes in Wooden Board



4.1.4 Accuracy test

The tests were conducted to determine the level of precision of CNC machine in making a particular shape. For this test, input was a profile “CNC” with 30 mm width and 60 mm length, which will be performed on a wood sample with 5 mm depth. The test was carried out using 3 mm vbit600 drill bit,with 12000 rpm spindle speed. The complete specification of job is shown in Table 3. The profile to be cut on specimen is shown in figure 7.

Figure 7: Profile for Measuring the Working Accuracy of Machine

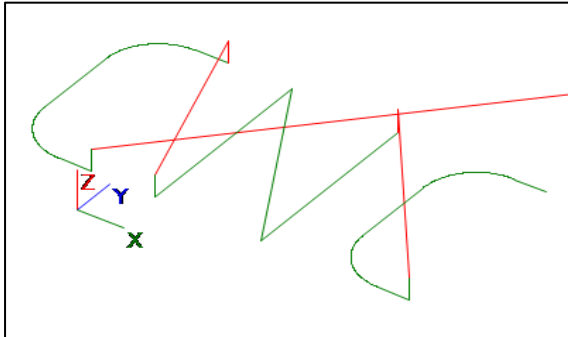

Figure 8: Machined Wooden Block with Profile

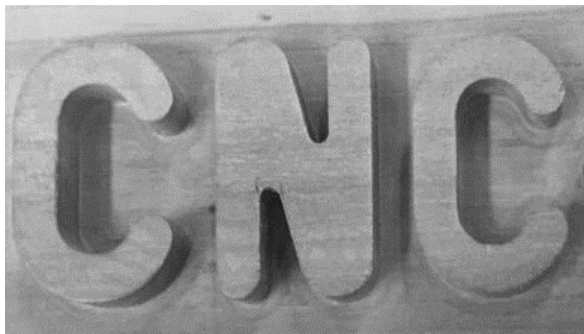

Table 4: Comparison of Obtained and Actual Depth of Machined Profile

Letter	Engraving Depth	Measured Depth	Accuracy
C1	5.000 mm	4.978 mm	98.94%
N	5.000 mm	5.034 mm	98.32%
C2	5.000 mm	4.986 mm	99.29%

Table 5: Comparison of Obtained and Actual Dimensions of Machined Profile

Letter	Engraving Width (mm)	Measured Width (mm)	Accuracy	Engraving Length (mm)	Measured Length (mm)	Accuracy
C1	30.000	29.961	99.87%	60.000	59.982	99.97%
N	30.000	29.893	99.64%	60.000	59.898	99.83%
C2	30.000	29.981	99.93%	60.000	60.025	99.95%

The output result of the machine is again measured using coordinate measuring machine with

accuracy upto 3 decimal places. The “CNC” profile cut out on the wooden block is shown in Figure 8 and results of depth and dimensions are reported in Table 4 and Table 5.

From the results obtained (Refer Table 4 and Table 5), it was observed that depth was machined with an average accuracy of 98.85%, length with an average accuracy of 99.91% and width with an average accuracy of 99.81%. It was observed that the operations done by tool was accurate with respect to the placement of coordinates, but the variations in depth was more due to various factors such as low dc motor torque, and vibrations while operating the machine.

5.0 Conclusions

The Mini CNC Milling machine was successfully fabricated using Arduino Uno R3 with AT Mega 328 chip, GRBL Shield, SMPS and stepper motors. The synchronization of three stepper motor drivers in X, Y and Z Axis was done using GRBL Driver and Universal G Code Sender Software combined with X Loader. The machine was used for performing various operations such as drilling, engraving, cutting, marking on wood and acrylic to form 2D or 3D profiles with 98.85% depth accuracy and average 99.86%-dimensional accuracy. This working CNC machine was successfully utilized in skill enhancement and hands on experience of students in the institute.

References

- [1] M Tolouei-Rad, S Zolfaghari. Productivity improvement using Special-Purpose Modular machine tools. *Int J Manuf Res.*4(2), 2009, 219–35.
- [2] DG Lee, JD Suh, HS Kim, JM Kim. Design and manufacture of composite high speed machine tool structures. *Compos Sci Technology*, 64(10), 2004, 1523–30.
- [3] S Anderberg, S Kara. Energy and cost efficiency in CNC machining. In: *The 7th CIRP Conference on Sustainable Manufacturing*: Chennai, India, December, 2009 2-4.

- [4] Computer Numerical Control Machines Market Size, Share & Trends Analysis Report By Type (Lathe Machine, Milling Machine), By End Use (Automotive, Power & Energy), By Region, And Segment Forecasts, 2019 – 2025. Report ID: GVR-2-68038-077-4 (<https://www.grandviewresearch.com/industry-analysis/computer-numerical-controls-cnc-market>)
- [5] AN Rai. Skill development programmed and women empowerment in India. *Journal of Current Science*, 19(64664), 2018, 1–5.
- [6] R Khanna, SP Singh. Status of MSMEs in India: A detailed study. *Journal of Applied Management-Jidnyasa*, 10(2), 2018, 1–14.
- [7] A Pinheiro, B Jose, T Chacko, N Tn. Mini CNC Plotter. *Int. Journal of Innovative Research in Electrical, Electronics, Instrumentation and Control Engineering* 4(4), 2016187–8.
- [8] SA Obayes, IR Al-Saedi, FM Mohammed. Prototype Wireless Controller System based on Raspberry Pi and Arduino for Engraving Machine. *UKSim-AMSS 19th IEEE International Conference on Computer Modelling & Simulation (UKSim) 2017*, 69–74.
- [9] A Quatrano, S De, ZB Rivera, D Guida. Development and implementation of a control system for a retrofitted CNC machine by using Arduino. *FME Transactions*, 45(4), 2017, 565–71.
- [10] S Karthik, PT Reddy, KP Marimuthu. Development of low-cost plotter for educational purposes using Arduino. *InIOP Conference Series: Materials Science and Engineering*, IOP Publishing, 225(1), 2017, 012019)..
- [11] RD Al Habsi, GR Rameshkumar. Design and Fabrication of 3-Axis Computer Numerical Control (CNC) Laser Cutter. *International Journal of Multidisciplinary Sciences and Engineering*. 7(5), 2016, 7-16.
- [12] PF Khan, S Sengottuvel, R Patel, A Mani, K Gireesan. Arduino-Based Novel Hardware Design for Liquid Helium Level Measurement. *SLAS Technology: Translating Life Sciences Innovation*. 23(5), 2018, 456-62.
- [13] J Braumann, SB Cokcan. Digital and physical tools for industrial robots in architecture: robotic interaction and interfaces. *International Journal of Architectural Computing*. 10(4), 2012541-54.